

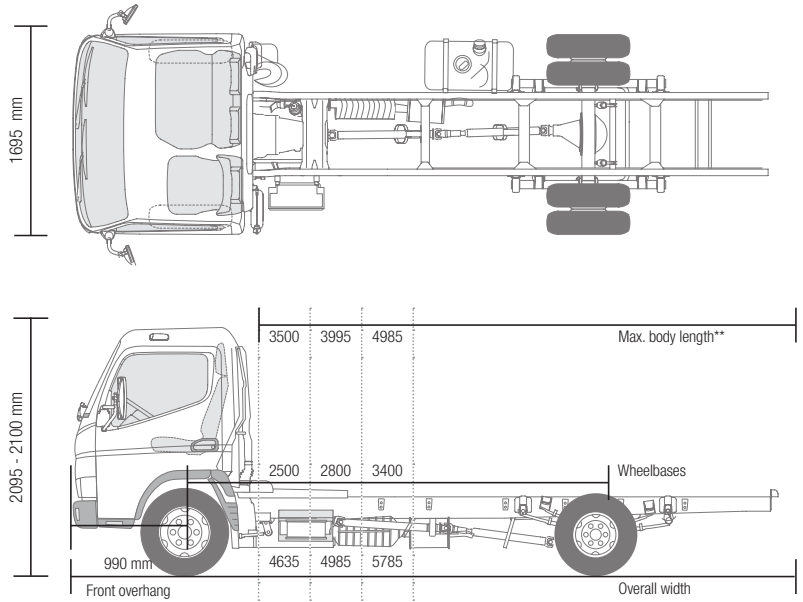

CANTER 3S13 DUONIC®



Mass/Dimensions							
Model	Vehicle type	3S13					
	Cab type / Crew	Standard, Single / 3					
	MB model code	46805211	46805311	46805511			
	FUSO model code	FEA01BL3SEAS	FEA01CL3SEAS	FEA01EL3SEAS			
DIMENSIONS mm							
Wheelbase		2500	2800	3400			
Overall length		4635	4985	5785			
Cabin length			1510				
Overall width			1700				
Cabin width			1695				
Overall height, approx.		2100			2095		
Tread	Front / Rear	1405 / 1255					
Frame height (back of chassis) approx.		715			710		
Ground clearance, approx.		165					
Cab to rear axle		1975	2275	2875			
Cab to frame end		3120	3470	4270			
Max. body length**		3500	3995	4985			
Frame width		700					
Front overhang		990					
Rear overhang (to frame end)		1145	1195	1395			
Front axle to beginning of body		625					
Recommended cab to body gap		100					
WEIGHTS kg							
Total curb weight*		1885		1890		1920	
	Front* / Rear*	1400	485	1405	485	1425	495
Minimum vehicle weight		2125	2130	2160			
Max. GVW / Max. GCW		3500 / 7000					
Axle loads	Front / Rear	1900 / 2500					
Trailing load	Braked / Non-braked	3500 / 750					
Chassis Payload		1615	1610	1580			
CALCULATED PERFORMANCE							
Max. speed w/o speed limiter	km/h	140					
Max. gradeability	(tan q)%	60					
Min. turning radius (m)	Curb to curb	9.0	10.0	11.8			
	Wall to wall	10.2	11.2	13.0			

* including coolant, oils, 90% fuel, spare tire, tools and 75 kg driver; ** calculated maximum value. Should be checked based on installed body and application
 Subject to change without notice. All the information in this data sheet should be viewed as indicative. The illustrations may show accessories and items of special equipment which are not part of standard specification. This data sheet may also contain models and services which are not available in certain countries.



CANTER 3S13 DUONIC®

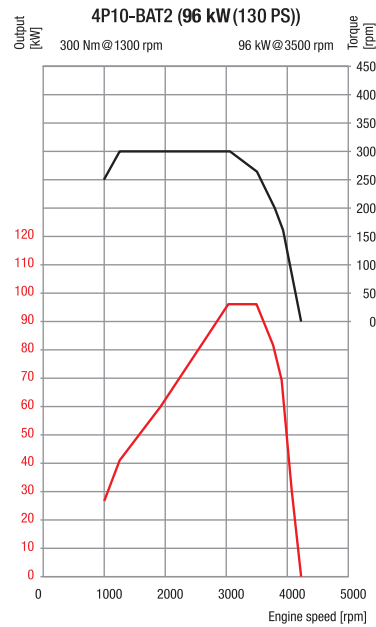

Engine/Drive Line/Chassis

ENGINE (Euro 5b+)		
Model	4P10-BAT2	
Type	4 stroke, turbo-charged water cooled direct injection diesel engine with intercooler	
No. of cylinders	4 in line	
Piston displacement	2998 cm ³	
Max. output (EEC)	96 kW (130 PS) / 3500 rpm	
Max. torque (EEC)	300 Nm / 1300 rpm	
Diesel particulate filter	Life span appr. 300000 km	
Alternator	A.C. 12 Volt, 140 Amp	
Emissions aftertreatment	EGR + DPF	
Emissions level	Euro 5b+	
PTO (as option)	Type	31 kW with flange 31 kW for direct connected pumps
	Torque at max power	196 Nm
	PTO Ratio	1:0.655 1:0.651
	PTO speed at max power	1500 rpm

DRIVE LINE

Transmission	Model	M038S6 (DUONIC® Dual-clutch automated manual transmission)
	Type	Automated Transmission, 6 forward and 1 reverse speed
	Gear ratio	5.397 - 3.788 - 2.310 - 1.474 - 1.000 - 0.701 Rev. 5.397
Final reduction gear	Ratio	4.111 (Opt. 4.444)

CHASSIS

Front axle / Rear axle	Model	F100T / R015T
	Rating	1900 kg / 2500 kg
Tyre		195/75R16C 107/105 R
		Single front, dual rear
Wheel		16 x 5 JK - 110
Steering		Left hand drive
		Steering bevel gear and power steering with rack & pinion gear, tilt and telescopic column with steering lock
Brake	Service	Hydraulic vacuum assisted 2 circuit split system
	Front / Rear	Disc (217 x 24)
	Parking	Mechanical, internal expanding type mounted on the rear end of the transmission case
	Auxiliary	Exhaust brake (50 kW)
Suspension	Front / Rear	Semi-elliptic laminated leaf spring with shock absorbers and stabilizer
Frame	Type	C-Profile ladder frame
Fuel tank capacity		70 l
Electrical system – batteries		12 Volt (100 AH - 760 A(EN))