

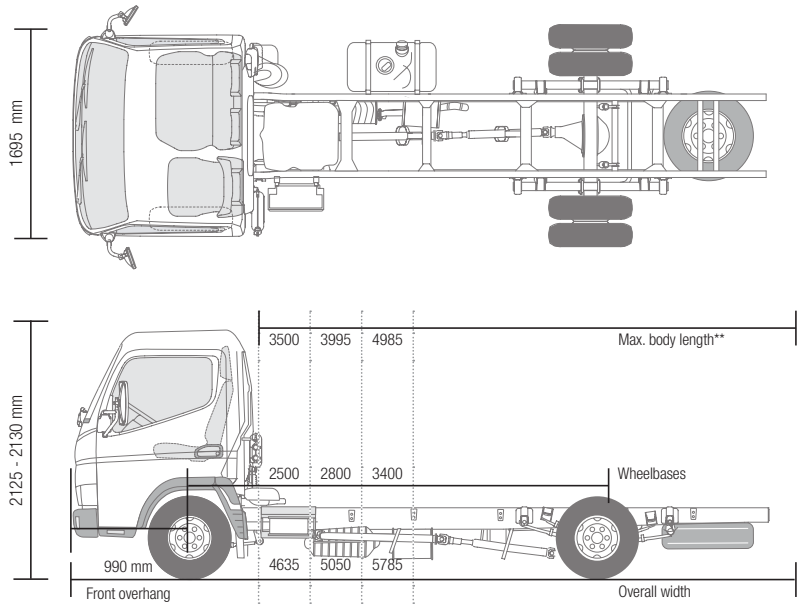

CANTER 6S15



Mass/Dimensions	
Model	Vehicle type
	Cab type / Crew
	MB model code
	FUSO model code

	6S15		
	Standard, Single / 3		
	46821212	46821312	46821512
	FEA51BL4SEAT	FEA51CL4SEAT	FEA51EL4SEAT

DIMENSIONS mm			
Wheelbase	2500	2800	3400
Overall length	4635	5050	5785
Cabin length		1510	
Overall width		1875	
Cabin width		1695	
Overall height, approx.	2130	2125	2125
Tread	Front / Rear	1390 / 1435	
Frame height (back of chassis) approx.	815	820	805
Ground clearance, approx.		165	
Cab to rear axle	1975	2275	2875
Cab to frame end	3120	3470	4270
Max. body length**	3500	3995	4985
Frame width		700	
Front overhang		990	
Rear overhang (to frame end)	1145	1195	1395
Front axle to beginning of body		625	
Recommended cab to body gap		100	

WEIGHTS kg						
Total curb weight*	2150		2165		2190	
	Front* / Rear*	1470 / 680	1480 / 685	1475 / 715		
Minimum vehicle weight	2340					
Max. GVW / Max. GCW	6000 / 9000					
Axle loads	Front / Rear	2300 / 4360				
Trailing load	Braked / Non-braked	3500 / 750				
Chassis Payload	3850		3835		3810	

CALCULATED PERFORMANCE			
Max. speed w/o speed limiter	km/h	141	
Max. gradeability	(tan q)%	33.5	
Min. turning radius (m)	Curb to curb	10.2	13.4
	Wall to wall	11.4	14.6

* including coolant, oils, 90% fuel, spare tire, tools and 75 kg driver; ** calculated maximum value. Should be checked based on installed body and application
 Subject to change without notice. All the information in this data sheet should be viewed as indicative. The illustrations may show accessories and items of special equipment which are not part of standard specification. This data sheet may also contain models and services which are not available in certain countries.



CANTER 6S15

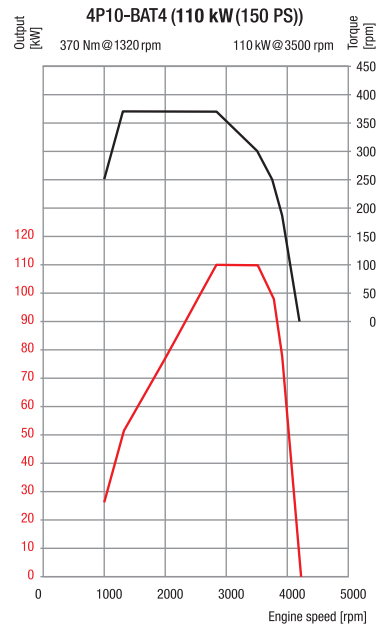

Engine/Drive Line/Chassis

ENGINE (Euro 5b+)		
Model	4P10-BAT4	
Type	4 stroke, turbo-charged water cooled direct injection diesel engine with intercooler	
No. of cylinders	4 in line	
Piston displacement	2998 cm ³	
Max. output (EEC)	110 kW (150 PS) / 3500 rpm	
Max. torque (EEC)	370 Nm / 1320 rpm	
Diesel particulate filter	Life span appr. 300000 km	
Alternator	A.C. 12 Volt, 140 Amp	
Emissions aftertreatment	EGR + DPF	
Emissions level	Euro 5b+	
PTO (as option)	Type	31 kW with flange 31 kW for direct connected pumps
	Torque at max power	196 Nm
	PTO Ratio	1:0.644 1:0.638
	PTO speed at max power	1500 rpm

DRIVE LINE

Transmission	Model	M038S5 (Manual transmission)
	Type	Manual, 5 forward and 1 reverse speed
	Gear ratio	5.494 - 3.193 - 1.689 - 1.000 - 0.723 Rev. 5.494
Final reduction gear	Ratio	4.444 (Opt. 4.875)

CHASSIS

Front axle / Rear axle	Model	F200T / R030T
	Rating	2600 kg / 4500 kg
Tyre		205/75R16C 113/111 Q
		Single front, dual rear
Wheel		16 x 5 1/2K - 115 - 8t - 5 stud
Steering		Left hand drive
		Steering bevel gear and power steering with rack & pinion gear, tilt and telescopic column with steering lock
Brake	Service	Hydraulic vacuum assisted 2 circuit split system
	Front / Rear	Disc (235 x 40)
	Parking	Mechanical, internal expanding type mounted on the rear end of the transmission case
	Auxiliary	Exhaust brake (50 kW)
Suspension	Front / Rear	Semi-elliptic laminated leaf spring with shock absorbers and stabilizer
Frame	Type	C-Profile ladder frame
Fuel tank capacity		70 l
Electrical system – batteries		12 Volts (100AH-760A(EN))