

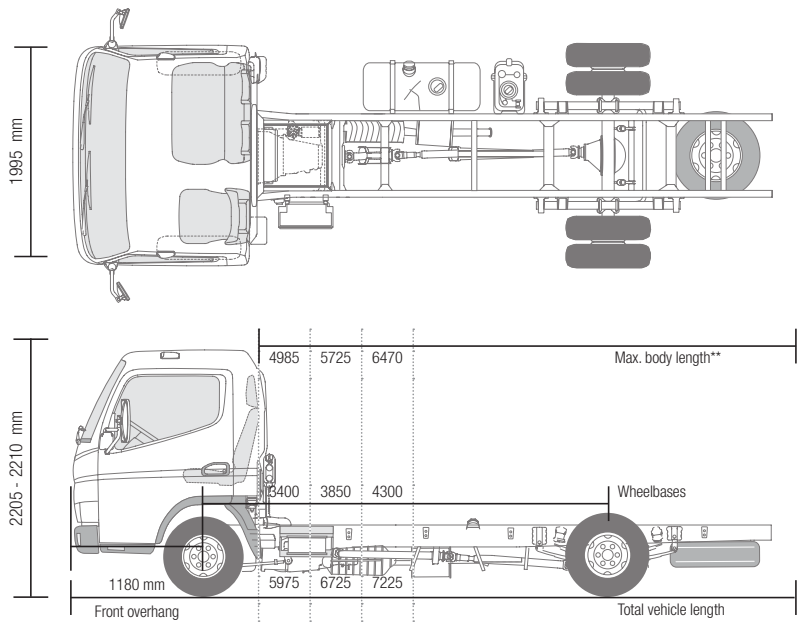

CANTER 9C15 DUONIC®



Mass/Dimensions

Model	Vehicle type	9C15		
	Cab type	Wide, Single / 3		
	MB model code	46850512	46850712	46850812
	FUSO model code	FECX1EL3SEAT	FECX1GL3SEAT	FECX1HL3SEAT

DIMENSIONS mm

Wheelbase		3400	3850	4300
Overall length		5975	6725	7225
Cabin length			1625	
Overall width			2135	
Cabin width			1995	
Overall height, approx.			2210	2205
Tread	Front / Rear		1665 / 1670	
Frame height (back of chassis) approx.		830	835	830
Ground clearance, approx.			185	
Cab to rear axle		2875	3325	3775
Cab to frame end		4270	5020	5520
Max. body length**		4985	5725	6470
Frame width			850	
Front overhang			1180	
Rear overhang (to frame end)		1395	1695	1745
Front axle to beginning of body			625	
Recommended cab to body gap			100	

WEIGHTS kg

Total curb weight*		2555	2570	2605
	Front* / Rear*	1680 / 875	1645 / 925	1680 / 925
Minimum vehicle weight			2650	
Max. GVW / Max. GCW			8550 / 12050	
Axle loads	Front / Rear		3100 / 6000	
Trailing load	Braked / Non-braked		3500 / 750	
Chassis Payload		5995	5980	5945

CALCULATED PERFORMANCE

Max. speed w/o speed limiter	km/h		125	
Max. gradeability	(tan q)%		30	
Min. turning radius (m)	Curb to curb	12.2	13.8	15.2
	Wall to wall	13.8	15.2	16.6

* including coolant, oils, 90% fuel, spare tire, tools and 75 kg driver; ** calculated maximum value. Should be checked based on installed body and application
Subject to change without notice. All the information in this data sheet should be viewed as indicative. The illustrations may show accessories and items of special equipment which are not part of standard specification. This data sheet may also contain models and services which are not available in certain countries.



CANTER 9C15 DUONIC®

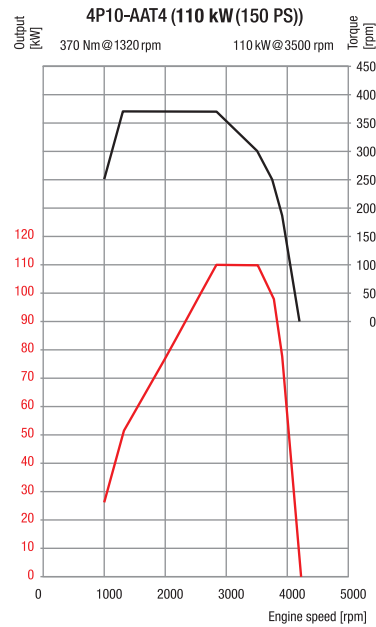

Engine/Drive line/Chassis

ENGINE (Euro VI)				
Model	4P10-AAT4			
Type	4 stroke, turbo-charged water cooled direct injection diesel engine with intercooler			
No. of cylinders	4 in line			
Piston displacement	2998 cm ³			
Max. output (EEC)	110 kW (150 PS) / 3500 rpm			
Max. torque (EEC)	370 Nm / 1320 rpm			
Diesel particulate filter	Life span approx. 300000 km			
Alternator	A.C. 12 Volt, 140 Amp			
Emissions aftertreatment	EGR + SCR + DPF			
Emissions level	Euro VI			
PTO	Type	31 kW with flange	62 kW with flange	31 kW for direct connected pumps
	Torque at max power	196 Nm	392 Nm	196 Nm
	PTO Ratio	1:0.655	1:0.727	1:0.651
	PTO speed at max power	1500 rpm		

DRIVE LINE

Transmission	Model	M038S6 (DUONIC® dual-clutch automated manual transmission)
	Type	Automated manual transmission, 6 forward and 1 reverse speed
	Gear ratio	5.397 - 3.788 - 2.310 - 1.474 - 1.000 - 0.701 Rev. 5.397
Final reduction gear	Ratio	5.714 (Opt. 6.166)

CHASSIS

Front axle / Rear axle	Model	F350T / R035T
	Rating	3100 kg / 6000 kg
Tyre		205/75R17.5C 124/122M
		Single front, dual rear, optimized rolling resistance tyres
Wheel		17.5 x 6.00 - 127 - 6 stud
Steering		Left hand drive
		Steering bevel gear and power steering with rack & pinion gear, tilt and telescopic column with steering lock
Brake	Service	Hydraulic vacuum assisted 2 circuit split system
	Front / Rear	Disc (252 x 40)
	Parking	Mechanical, internal expanding type mounted on the rear end of the transmission case
	Auxiliary	Exhaust brake (50 kW)
Suspension	Front / Rear	Semi-elliptic laminated leaf spring with shock absorbers and stabilizer
Frame	Type	C-Profile ladder frame
Fuel tank capacity		100 l
Electrical system – batteries		12V-100AH (760A EN)